

Spraykula S30

2019-01-23



- Utmärkt rengöring
- Låg vattenförbrukning
- Roterande sprayhuvud
- Varierande sprayvinklar
- Varierande anslutningar
- Dubbla kullagerbanor

Artikelnummer 2920-S30...

Teknisk Data	
Anslutning:	Gänga, svets, clip-on
Sprayvinkel:	90° / 180° / 360°
Rek. Ø för rengöring:	0.5-2.0 meter
Arbetstryck:	1.0-9.0 bar
Max media temp:	230°C
Max omgivn.temp:	250°C
Material:	316L

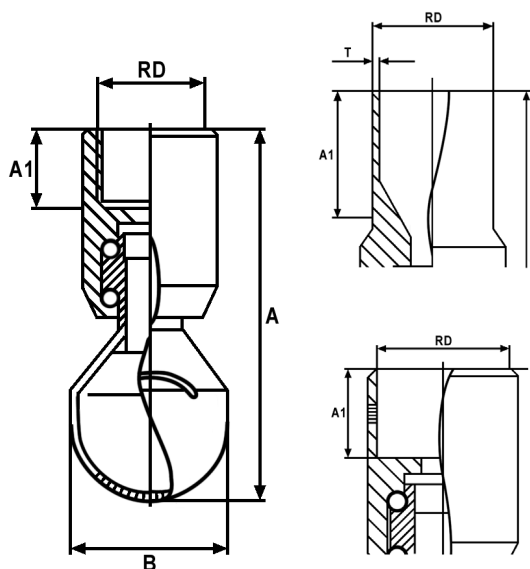

Ansl.	DN mm	A mm	B mm	RD mm	A1 mm	T mm
Gäng	10	60	28	G 3/8"	10.5	---
Svets	15	83	28	19.05	26.0	1.65
Clip-on	15	60	28	18.3	10.5	---
Clip-on	15	60	28	19.3	10.5	---

TANKO®-S30 Flödesdiagram

